

Duck Roaster



DRO-1A-GHR-CE

New Concept

Heat Radiant Roasting Concept

Energy Saving

Equipped with powerful burner and heat radiant type panel that needs only 5 minutes to heat up and ready to use. 300% faster in heat-up time than traditional roaster.

High Efficiency

Even heat distribution of roaster surface provides better quality of roasting. Detachable lava rock stand holding rocks that retains remained heat after flame cut off to dry up duck/ chicken skin.

Hygiene

Removable panel can easily be cleaned.

Safety

Built-in Flame Failure Device to ensure safety operation. Front protection panel to keep away operators from hot surface of the roaster body.

Flexibility

Height adjustable of the heat radiant panel provides a more flexibility for applying different gas fuel.

Durability

High quality stainless steel panel provides a longer life span.

CAUTION

Operator must not put any lava rock, charcoal and/or other solid obstacles and/or splash water on heat radiant top during operation and combustion. Fail to do so, will result in badly damage the life span of heat radiant panel.

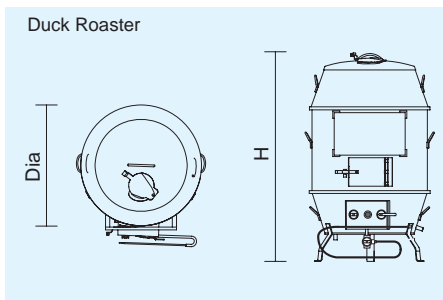
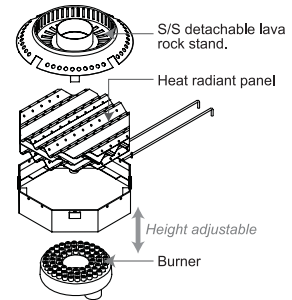

Diagram of burner with heat radiant panel & detachable lava rock stand.



Heat radiant panel



Specifications of Duck Roaster					
CE	Single layer body		Double layer body with fibre glass wool insulation		
	Model	DRO-1A-GHR-CE	DRO-2A-GHR-CE	DRO-1AD-GHR-CE	DRO-2AD-GHR-CE
Dimensions (mm)					
Diameter x Height	Ø810 x 1500	Ø910 x 1500	Ø865 x 1500	Ø965 x 1500	
Operating Pressure (mbar) / Heat input kW (BTU / hr.)					
G110 (Town Gas)					
I _{1a}	8mbar		14 (47770)		
G30 Butane / G31 Propane (L.P. Gas)					
I ₃₊ (28-30/37)	28-30 / 37mbar		14 (47770)		
I _{3B/P} (30)	30mbar				
I _{3B/P} (37)	37mbar				
I _{3B/P} (50)	50mbar				
G20 & G25 (Natural Gas)					
I _{2E} ; I _{2E+} ; I _{2H}	20mbar		14 (47770)		
I _{2L}	25mbar				
Fuel Pipe Connection (mm)					
Town Gas			Ø20		
Butane / Propane (L.P. Gas)			Ø20		
Natural Gas			Ø20		
Insulation (mm)		Nil		25	
Net / Gross Wt. (kgs)		68 / 136	82 / 160	102 / 170	123 / 205

Remark: Fuel suit for: Town Gas, Natural Gas, Butane/Propane (L.P. Gas). (must specify gas type before ordering).